

06/2015

Mod: EF102-TN

Production code: F17NVT 88LG TR CON



Diamond
catering equipment

Fryers

Mod.: EF102-TN

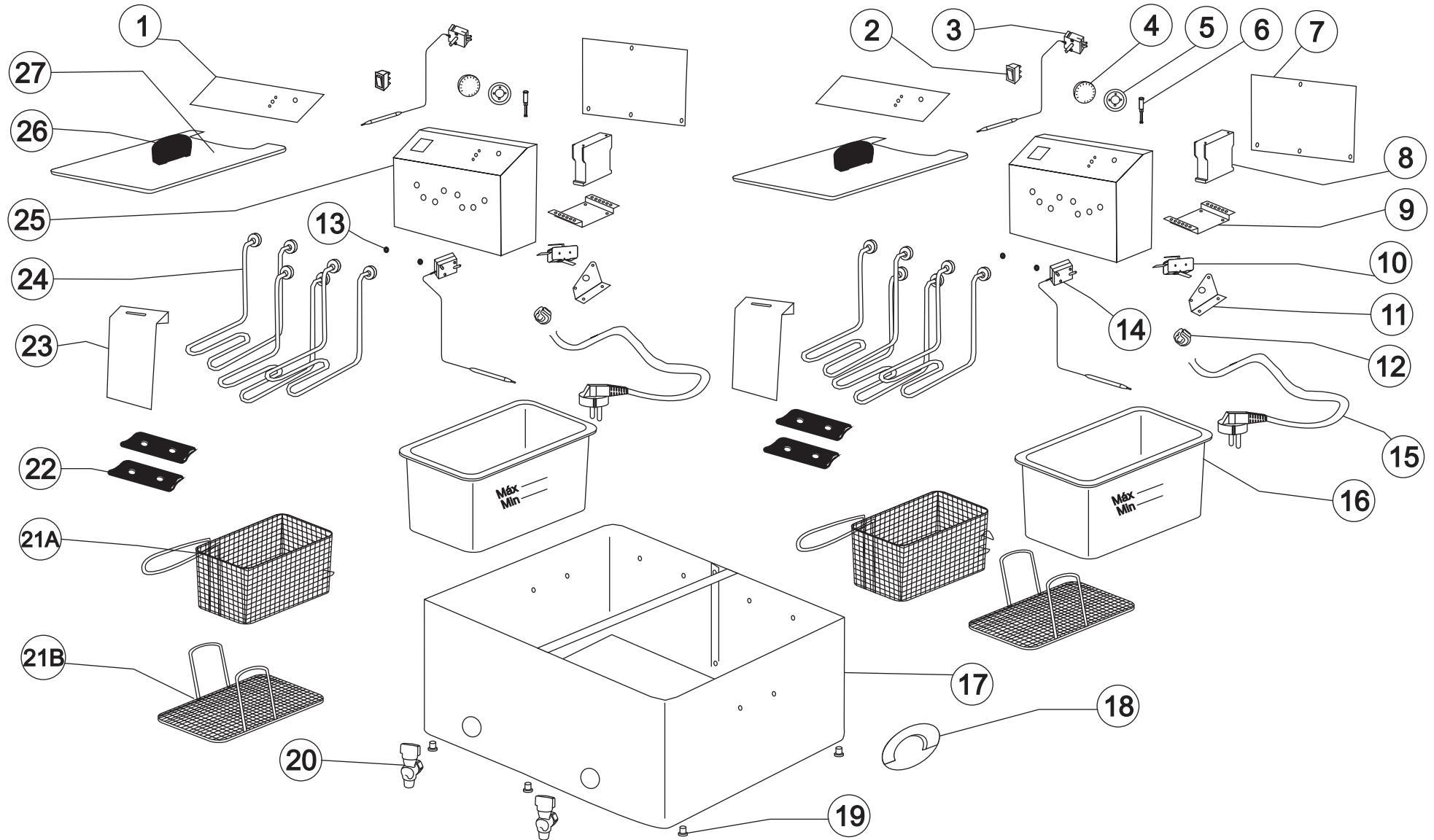

Part List Fryer Mod. EF102-TN

| Item # | code | Designation | Qty |
|---------------|----------------|-------------------------------------|------------|
| 1 | 08AP103 | Control label 8TRIF Diamond | 2 |
| 2 | 07IU005 | Switch 2 poles 16A | 2 |
| 3 | 07TR000 | Regulating thermostat w/ sensor 16A | 2 |
| 4 | 06BT004 | Thermostat knob Mod.5 | 2 |
| 5 | 109ES000 | Knob accessorie | 2 |
| 6 | 07SL000 | Pilot light Green 230V | 2 |
| 7 | 109TPFI708 | Panel back cover FI708 | 2 |
| 8 | 07CT000 | Relay 230V 3x9A | 2 |
| 9 | 07CL000 | Relay support | 2 |
| 10 | 07IS001 | Safety switch | 2 |
| 11 | 109SPMS2 | Safety switch support | 2 |
| 12 | 06CC003 | Strain relief 2,5mm ² | 2 |
| 13 | 06CC004 | Sensor wire ruber gland | 4 |
| 14 | 07TS003 | Safety thermostat w/ sensor 16A | 2 |
| 15 | 07CA014 | Power cord 5x2,5mm ² | 2 |
| 16 | 109CU8TR | Oil container 8L w/tap | 2 |
| 17 | 119BL88TRNV | Body 88L w/tap NV | 1 |
| 18 | 06PG003 | Body handle | 2 |
| 19 | 06TA002 | Rubber feet w/ screw | 6 |
| 20 | 09TR000 | Safe Tap | 2 |
| 21A | 09CST8LNIQ | Basket 8L | 2 |
| 21B | 09FLT8LNIQ | Filter 8L | 2 |
| 22 | 06PG002 | Basket handle | 2 |
| 23 | 109HC8TRIF | Heating element cover 8TRIF | 1 |
| 24 | 07RE018 | Heating element 1500W/230V | 6 |
| 25 | 119PNFI708TRIF | Control panel FI708TRIF | 2 |
| 26 | 06PG004 | Lid handle | 2 |
| 27 | 109TE8TRIF | Lid 8TRIF | 2 |
| 28 | 107CE708TRIF | Cabling 4500W-400V (230/3) | 2 |